

3-phsep - DYNAMIC SIMULATION OF OIL-GAS SEPARATION PLANTS

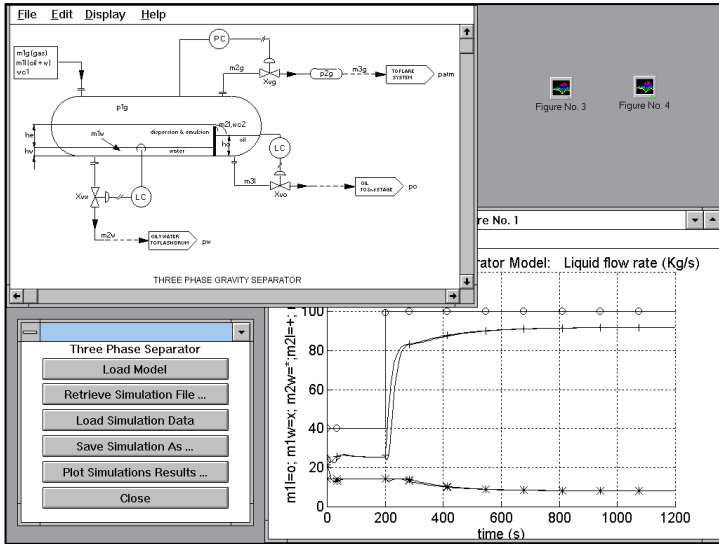

OVERVIEW

Oil and gas production plants simulation is becoming of increasing importance to allow innovative or smaller plants to be installed on offshore platforms or subsea. These may be more sensitive to transients occurring when slug flow conditions build-up.

Multiphase pumping units and well testing, sometimes integrated with small two-phase separators or slug catchers, are even more sensitive to slug flow and require high performance control systems to maintain the plant and the machines within pre-set operating ranges. Plant simulations by mathematical models suitable to describe complex phenomena, often non linear, are at reach of today's technology and cost effective. It may help at various stages, from preliminary to final system design.

Costly design or equipment changes can be prevented by early identification of potential operational problems and correct definition of the control strategy and units requirements.

PRODUCT DESCRIPTION

3Ph-sep is a MATLAB-SIMULINK® application providing the dynamic simulation of two and/or three-phase gravity separators performances, i.e. physical and control variables, which affect system's design and operations management.

Typically, the actual flow rate response of the system, stream characteristics (thermodynamic properties, concentrations, fluid velocities and flow rates), liquid levels and valves positions are plotted in comprehensible formats as function of time, for sets of pre-defined procedures or events (GOR and/or water cut variations, inlet flow changes, failure of assigned components, etc.). These information help system's designer to undertake proper corrective actions.

SCOPE OF THE 3PH-SEP SIMULATIONS

Separation systems simulations aim at identifying the response of the system in terms of pressure, temperatures, levels, phases concentrations (liquid carry-over, gas carry under, oil-in-water and water-in-oil) and flow rates variations at the outlet, on occurrence of input flow or boundary conditions changes or of components failures.

Proper consideration of the mutual interactions among physical units and controllers is paid, as when Single Input Single Output controllers are adopted, each controller may cause a disturbance to the other loops and undesired or too long transients.

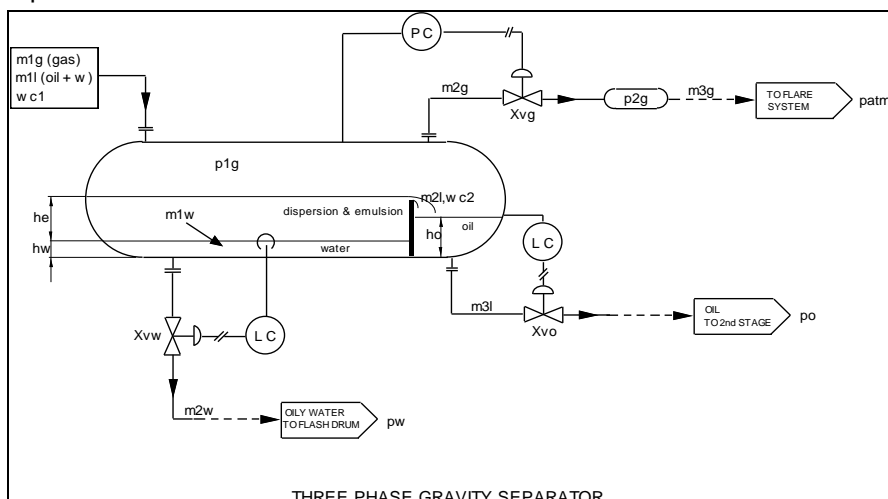

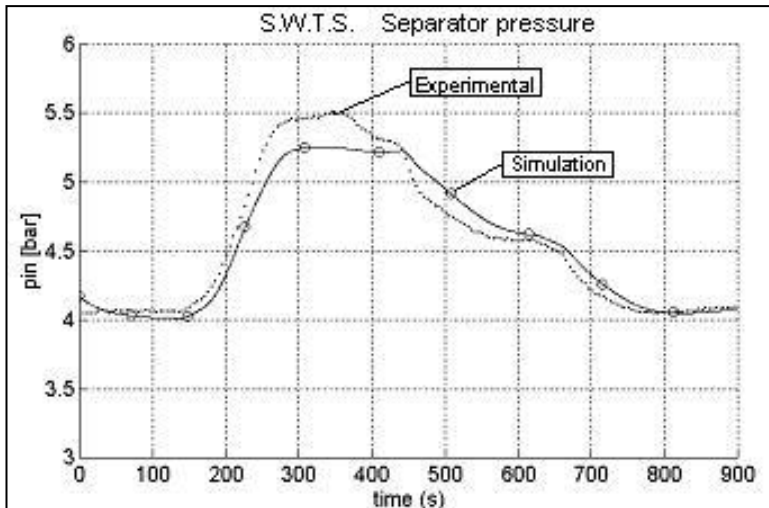
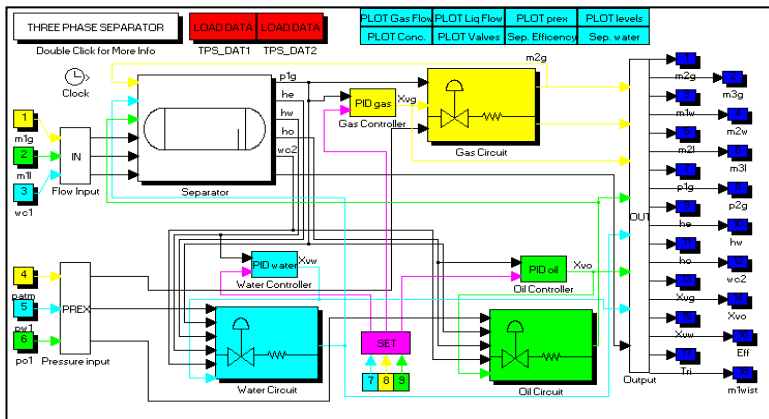

3-PHSEP MODEL OUTLINE

The separator and its control devices are modelled by a set of mathematical equations, including non linearities, and implemented using pre-defined and tailor made functional blocks in an object oriented mathematical environment, fully controllable during the numerical process.

The functional blocks performances are tested separately before integration over a wide range of conditions, to assure robustness of the model also under anomalous conditions (e.g. flow reversals, abnormal levels or retention times).

Testing of the model or its components is performed under assigned steady or dynamic conditions, derived from experiments or literature data. For poorly documented components sensitivity analyses can be made to assure the overall model performance to conveniently describe the actual system.

Separation efficiency is calculated as function of droplet/bubbles statistics in the respective phases, depending on the inlet multiphase flow conditions, on the fluids physical properties, thus on the dispersed rising/falling speeds of bubble/droplets size and flow regime.

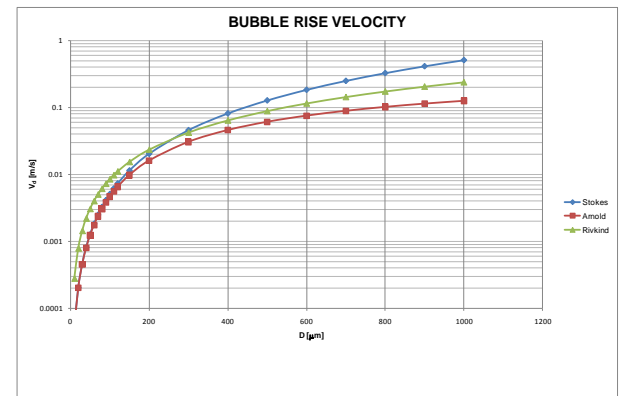

S.A.T.E. - Systems and Advanced Technologies Engineering S.r.l.

Santa Croce 664/a
30135 VENEZIA (ITALIA)
C.F. e P.IVA : 03040950275

Cap. Soc. : € 39 000 (interamente versato) – Iscr. CCIAA di Venezia, REA 25294/1998

tel.: + 39 - 041 2757634
fax: + 39 - 041 2757633
E-mail: info@sate-italy.com